BETA MARINE



Saildrives

Beta 14 to Beta 60

**Installation
Guidelines &
Operators Manual**

SeaProp 60 Saildrive

▼ BETA SAILDRIVE RANGE

The Beta 14 to the Beta 60 range of engines is available with the SeaProp 60 Saildrive leg.

This is generally supplied as a replacement to suit an existing installation with a GRP saildrive moulding. We also offer our GRP base as an option to enable installation in a standard in-board hull.

At first glance it may appear that the installation of the GRP base is complicated, but this is not normally correct. These instructions should be sufficiently detailed to enable the installation of the GRP base by most people. If you have any doubt, please ask your local Beta Marine dealer or your preferred marine engineer.

Installation Guidelines

▼ INSTALLATION - OVERVIEW

These are basic guidelines to assist installation; however due to the great diversity of marine craft it is impossible to give definitive instructions for each installation.

Therefore Beta Marine cannot accept responsibility for any damage and/or injury incurred during the installation of a Beta Marine engine whilst following these guidelines.

The marine engineer who installs the saildrive must be technically and practically competent with the modification and repair of glass fibre hulls and have the ability to complete the installation ensuring the total safety of the vessel.

⚠ IMPORTANT!

After installing the Saildrive into your boat it is very important that the installation is carefully checked for any problems or leaks both before and after your first sea trial.

▼ CUTTING THE GRP BASE TO SUIT THE HULL

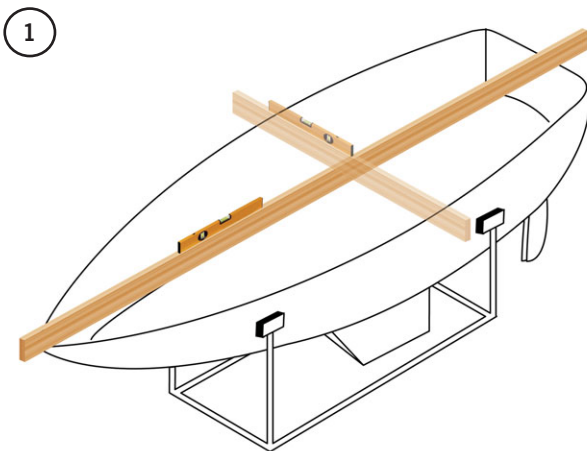

Level the boat hull.

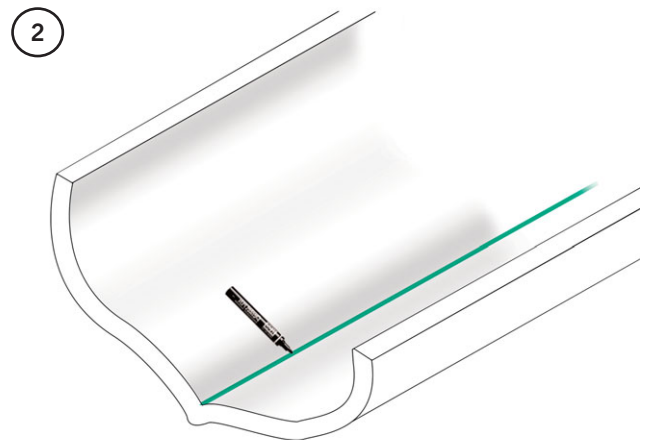

Mark the centre of the boat hull.

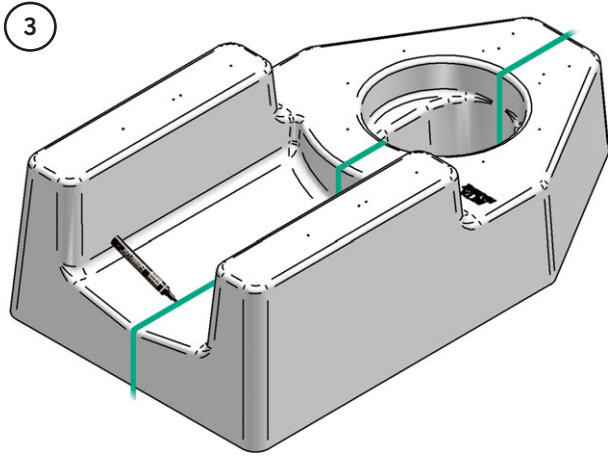

Mark the centre of the GRP base.

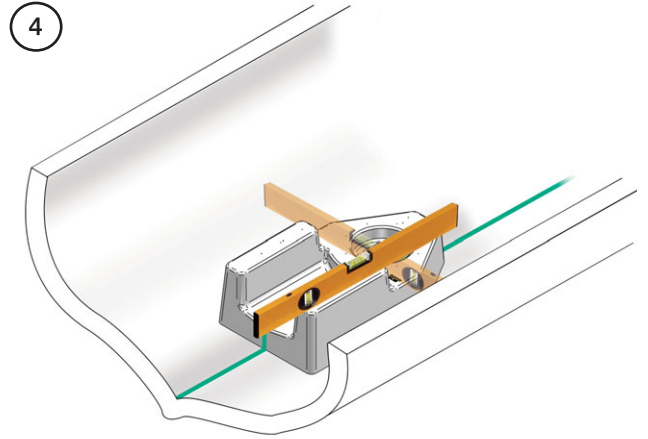

Position the GRP base in the boat hull making sure all is level with the water line

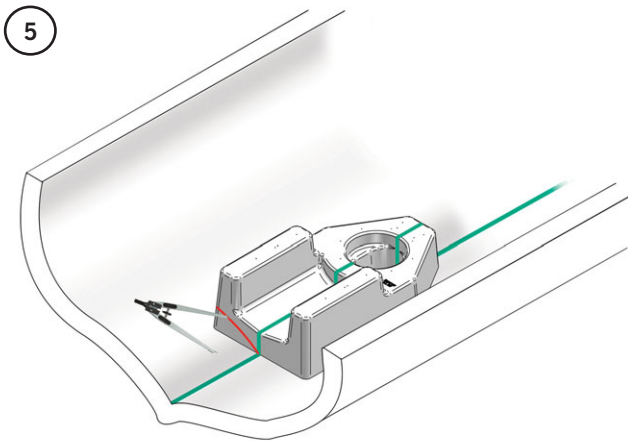

Use a block or marker and mark the base as shown.

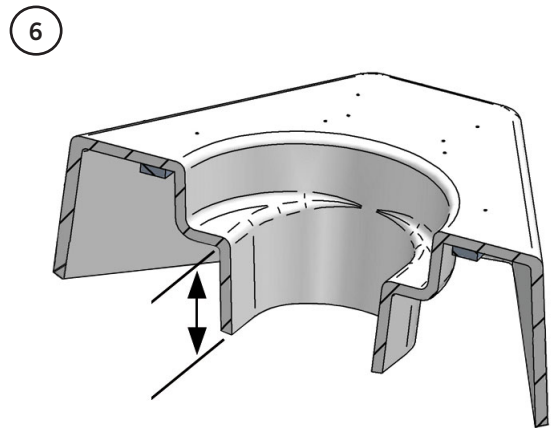

Carefully calculate and measure the inside of the GRP base to the outside of the hull to make sure that the propeller will not hit the boat hull when fitted.

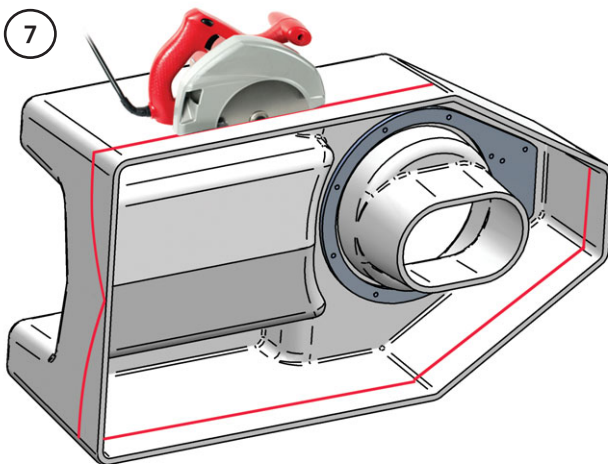

Cut the Saildrive base and clean.

▼ CUTTING THE HULL FOR SAILDRIVE MOULDING

8

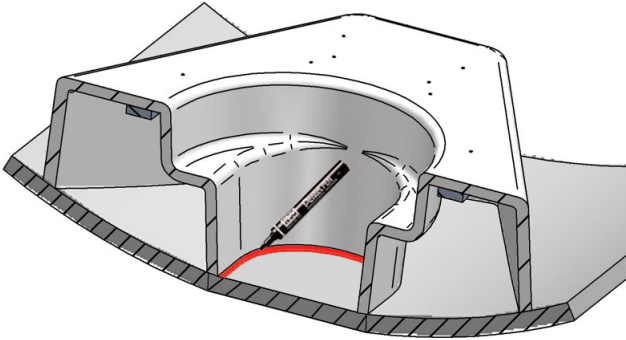

Put the base in position in the hull and mark the boat hull for cutting.

9

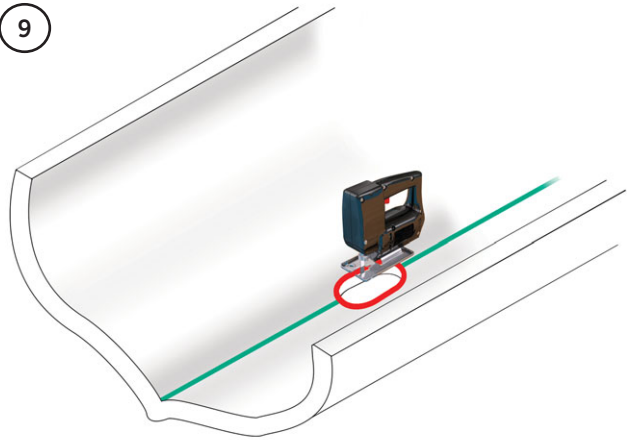

When certain of the correct position, cut the boat hull and clean.

▼ FITTING THE SAILDRIVE RING TO GRP MOULDING

10

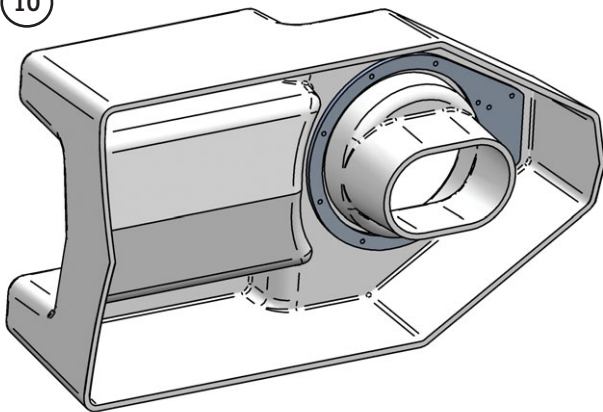

The aluminium saildrive ring must now be fitted into the GRP base. Use the Saildrive ring as a template to mark out the position of the holes and then drill the GRP base with 10.5mm holes to receive the Saildrive ring and studs.

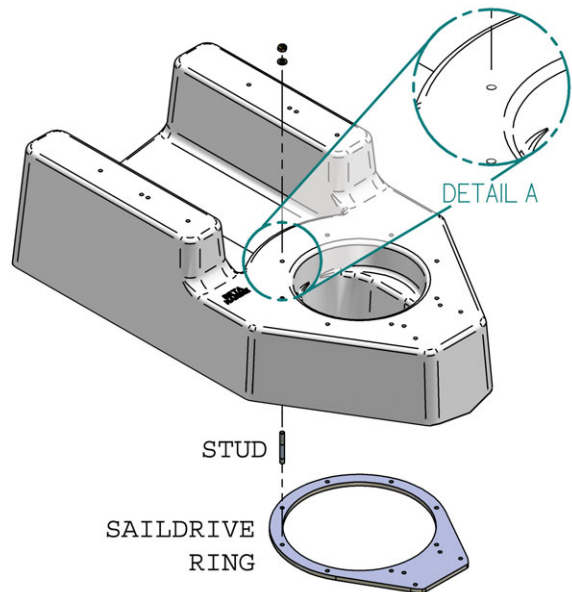

Screw the studs into the ring and put it in position so that the studs are protruding through the GRP base (the studs can be used to hold the saildrive ring in position for 'glassing-in').

11

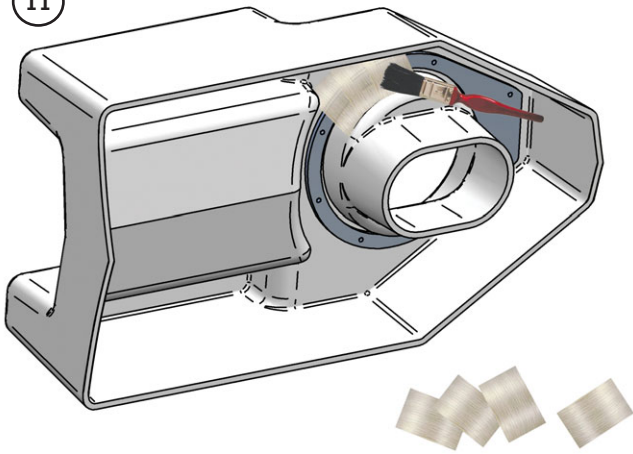

“Glassing-in” the ring.

12

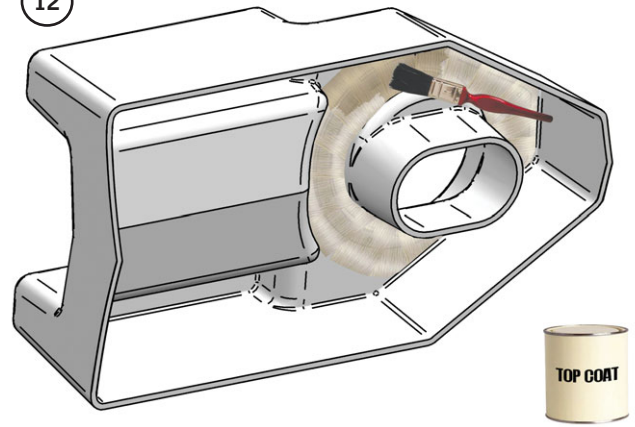

Apply top coat.

▼ FITTING THE GRP MOULDING INTO THE HULL

13

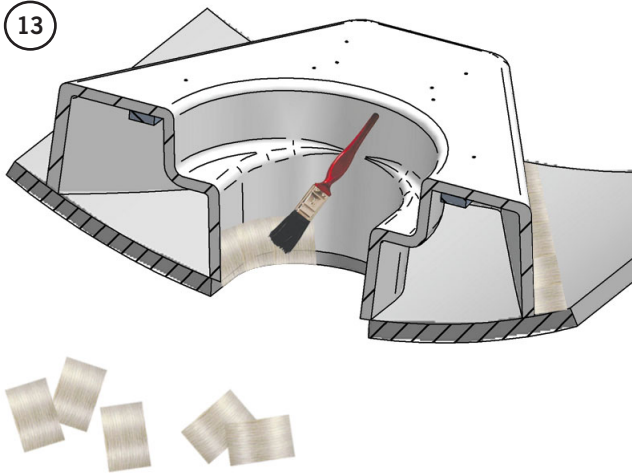

Put the GRP base back into position in the boat and “glass-in”.

14

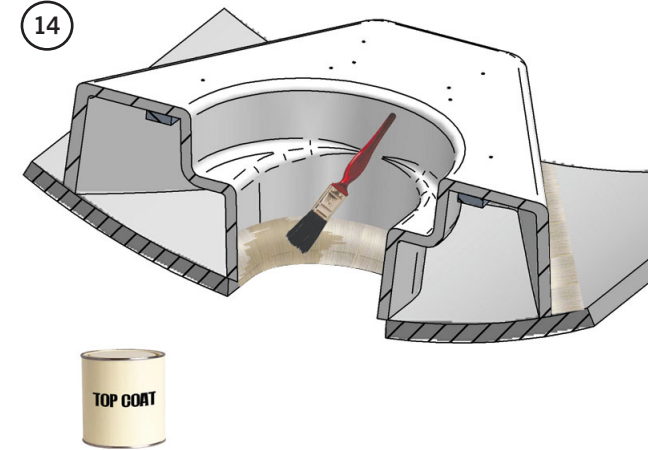

Apply top coat.

▼ INSTALLING THE SAILDRIVE UNIT

15 You may have space or lifting limitations for fitting the complete saildrive unit into position.

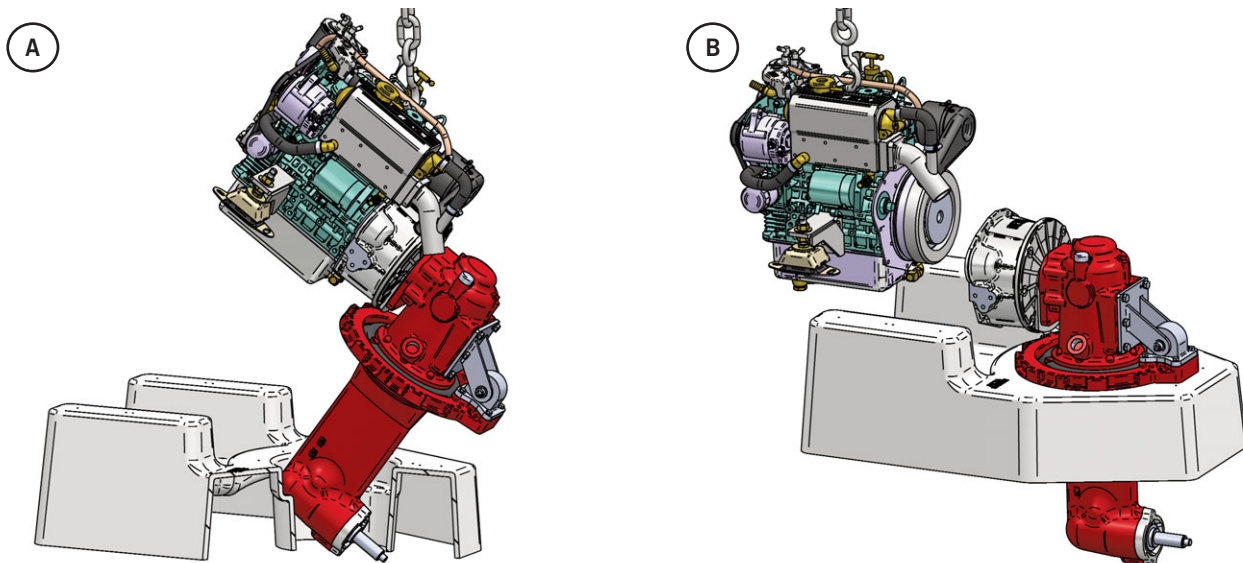

A: If you have enough room and suitable lifting gear you may be able to install the complete saildrive unit into the base in one go.

B: However if you have space or weight limitations you may need to split the saildrive leg from the engine and install the saildrive leg first. Then you must couple the engine to the Saildrive leg.

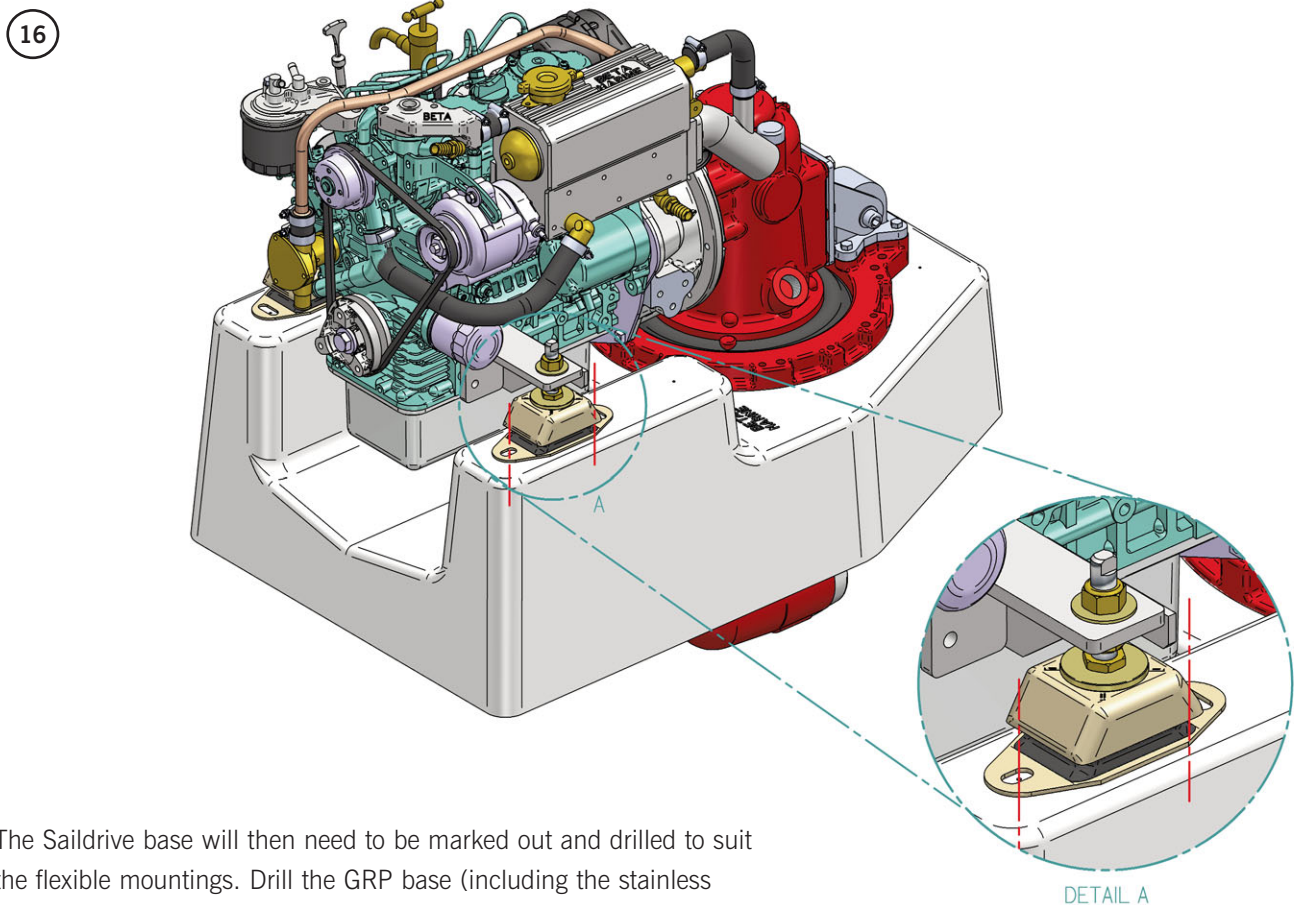

The Saildrive base will then need to be marked out and drilled to suit the flexible mountings. Drill the GRP base (including the stainless steel insert) 8.75mm and then tap the holes M10 as detail A shows.

▼ OPTIONAL RUBBER SEAL

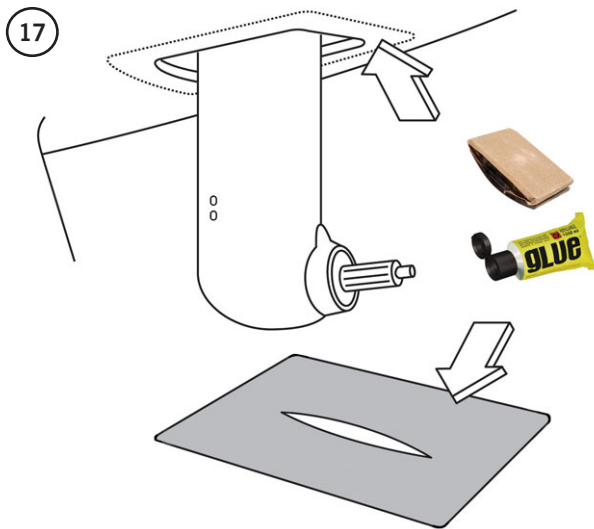

Use a piece of sand paper to rough up both boat hull and rubber insert / seal as shown; clean and apply a suitable glue.

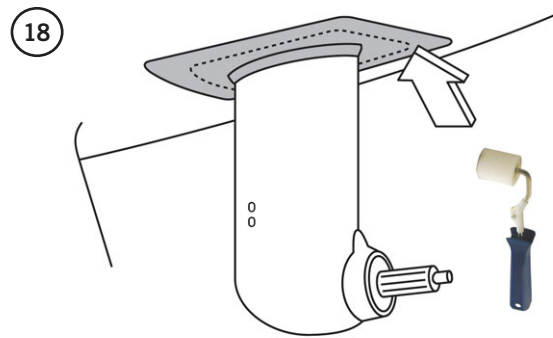

When the rubber insert / seal is fitted to the hull, use a roller the press all the air out and make a good joint.

▼ CONNECTION THE OPTIONAL CONTROL CABLE

Connect one side of cable to the dashboard control lever (adjust while in neutral position). Next connect the opposite side of the cable to the Saildrive lever (in neutral position).

Fit the retaining sleeve on the cable and fix with the fastener, screw on the cable threaded end and screw head until its hole aligns with shift lever fixing pin hole. Secure nut on head. Fit fixing pin on head and add the securing split pin.

Secure the retaining sleeve on control cable racket. Shift the lever from the dashboard. Check and adjust the cable so that the forward and reverse position match with the forward and reverse detent position of the Saildrive lever.

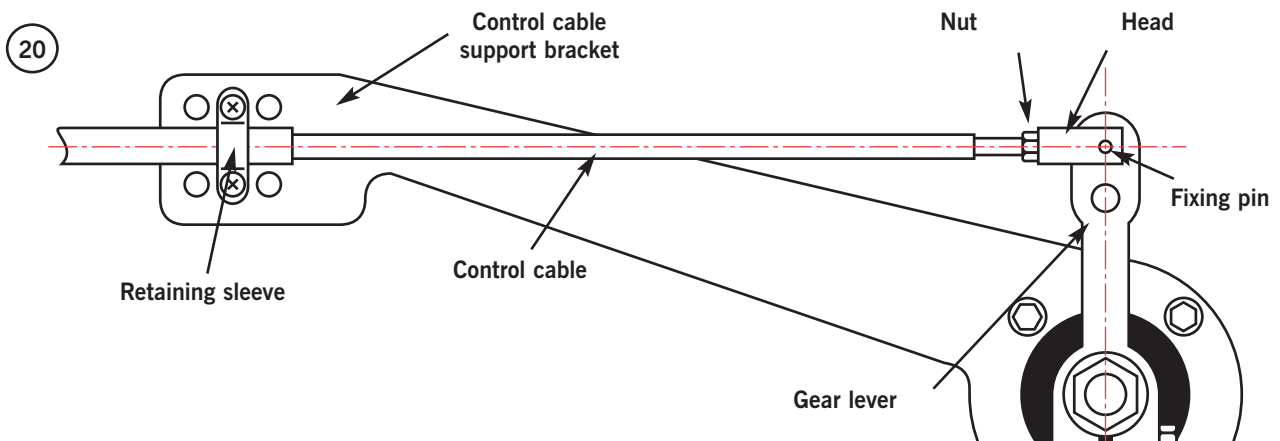
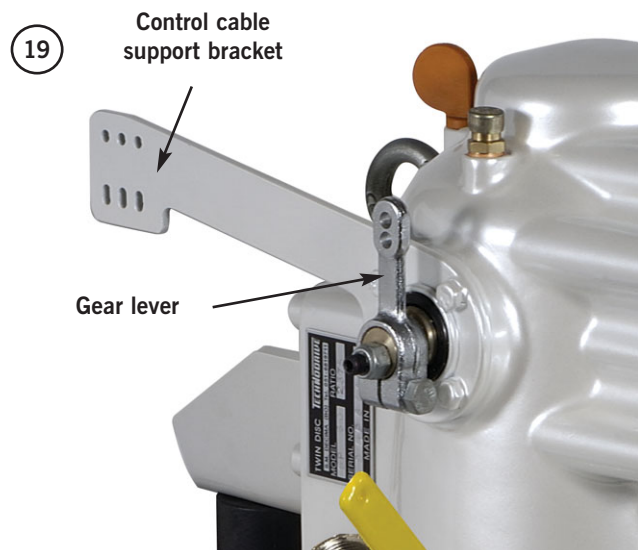

▼ FILLING THE LUBRICATING OIL

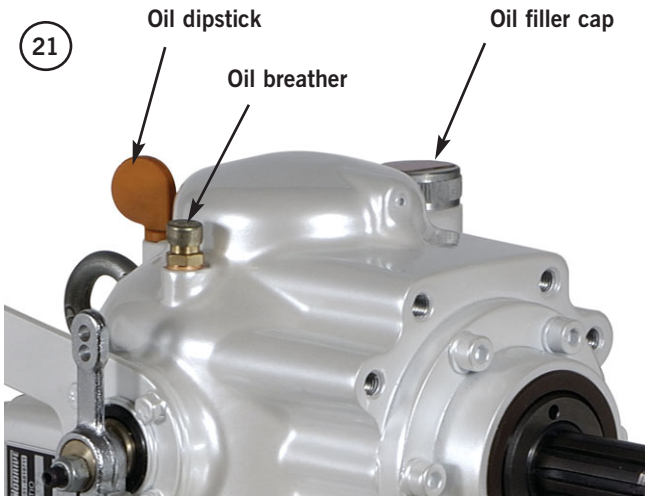

Lubricate the unit, with automatic transmission fluid (ATF). Recommended minimum quantity:

Saildrive Unit	Lubricant	Capacity (approx.)
SeaProp 60	Use ATF Oil	2.50 litres min. 2.65 litres max

▼ CONNECTING THE OPTIONAL WATER SENSOR

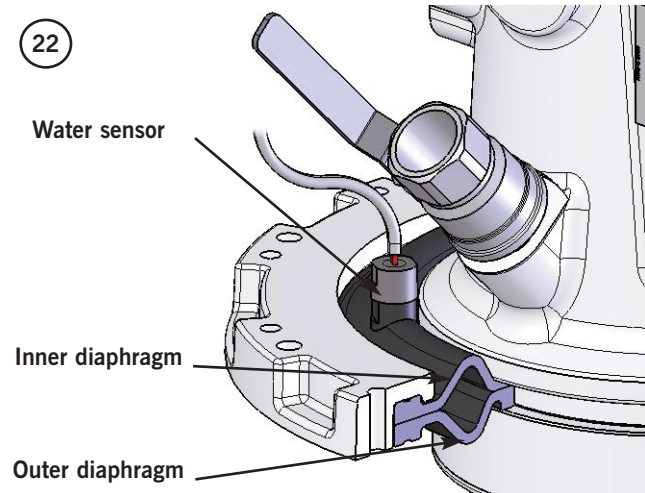

Connect the water sensor (normally opened contact 12/24V DC) to an alarm signal (snooze or light bulb) on dash board.

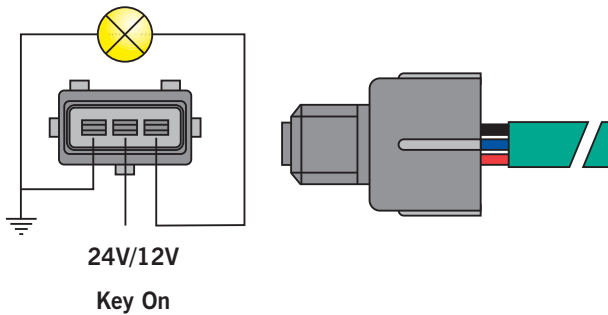

▼ INSTALLATION OF OPTIONAL FOLDING PROPELLER

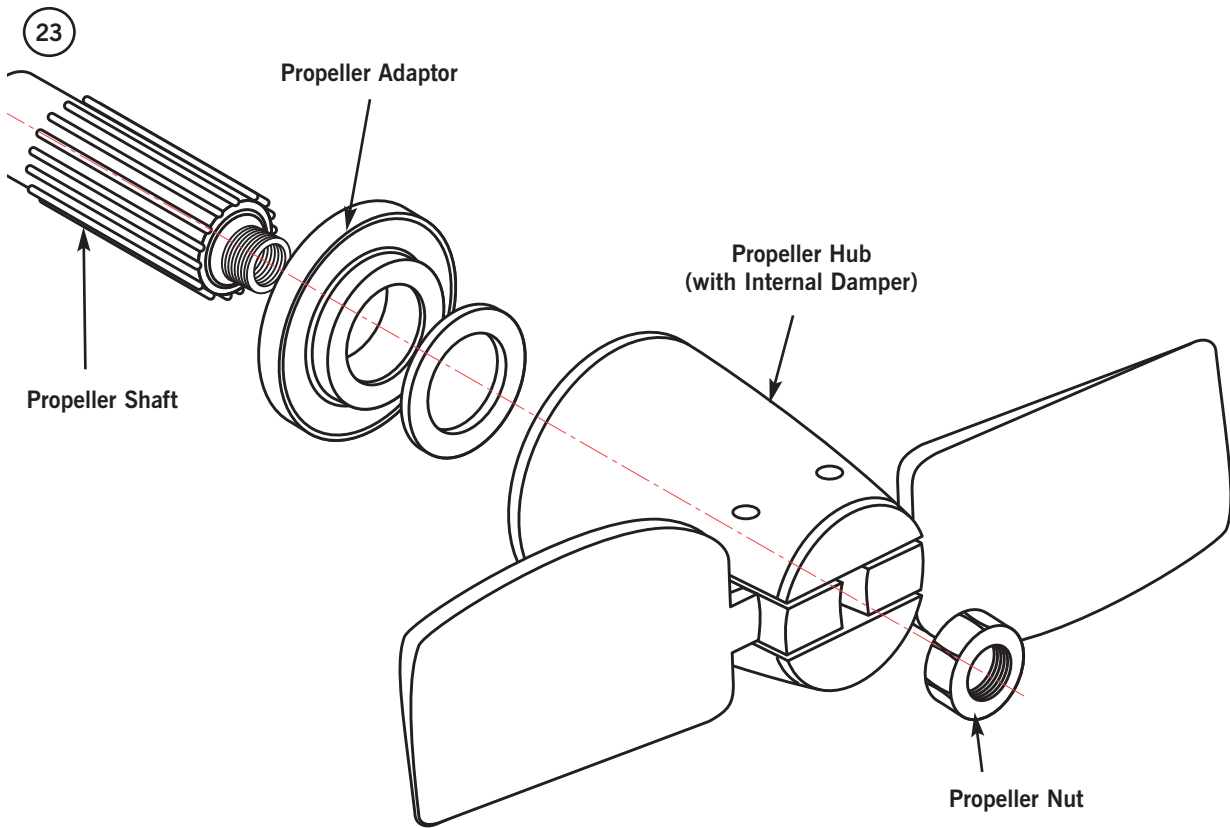

▼ INSTALLATION OF OPTIONAL FIXED PROPELLER

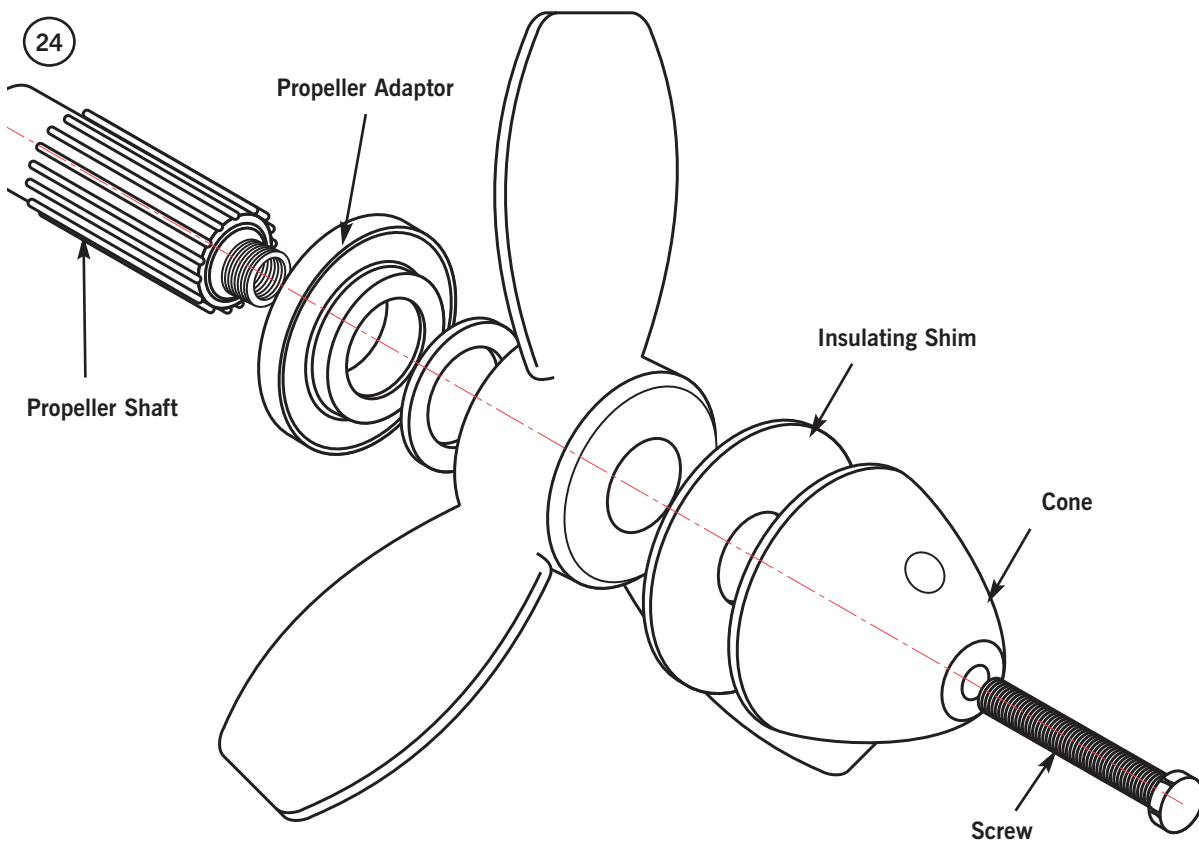

▼ ANTIFOULING PROTECTION

Outboard drives can be generally affected by Galvanic corrosion (this happens when two dissimilar metals are immersed in an electrolyte, and are electrically connected). The oxide layer, which gives the grey-white colour to aluminium, offers some protection against corrosion.

Nevertheless, this is not the ultimate protection, for two reasons. First, this layer can be damaged by abrasive actions or scratches that allow moisture to attack and corrode the metal before a new layer of oxide forms. Second, the oxide itself can be corroded by many different seawater salt components.

A better form of protection for the saildrive leg can be provided by painting it with 2 or more layers of special two pot outboard "antifouling" paint. Talk to your local chandler.

WARNING!

Do not paint the saildrive leg zinc anode and tail (propeller) cone anode.

▼ SAILING WITH ENGINE STOPPED

Always put the control lever into reverse when sailing. This will stop the shaft from rotating and will allow a self-feathering or folding propeller to feather.

A solid propeller will also give less drag if stopped, and to avoid lubrication problems the propeller must always be held in reverse when sailing long distances.

WARNING!

Continuous sailing with the saildrive unit not in the stopped / neutral position should not exceed 7 hours. Switch on engine and allow to run at idle for approximately 15 minutes to lubricate the saildrive transmission.



BETA MARINE

Genuine Beta Marine Filter Spares

- Available through our dealer network or direct from us.
- Beta Marine filters are thoroughly tested for quality.
- We require that Genuine Beta Marine filters are used or the engine warranty becomes invalid.
- We know that you can find cheaper filters from the Far East, but will they provide a warranty for their filters and our engine?

www.betamarine.co.uk

Tel: 01452 723492 Email: sales@betamarine.co.uk

Maintenance Schedule

	After First 25 Hours	After First 50 Hours	Every Year or 25 Hours if sooner	Every 750 Hours
Check lubrication oil level	●	●	●	●
Change lubrication oil	●		●	●
Check "sacrificial" zinc anode and replace if necessary		●	●	●
Tighten propeller retaining nut		●	●	●
Check and clean water inlets		●	●	●
Check rubber diaphragm seal		●	●	●
Check general condition		●	●	●

INSPECTIONS

For those engines where the fresh water circuit uses the saildrive leg's water inlets always inspect, (when boat out of water) that they are free from fouling.

▼ REPLACING THE ZINE ANODE

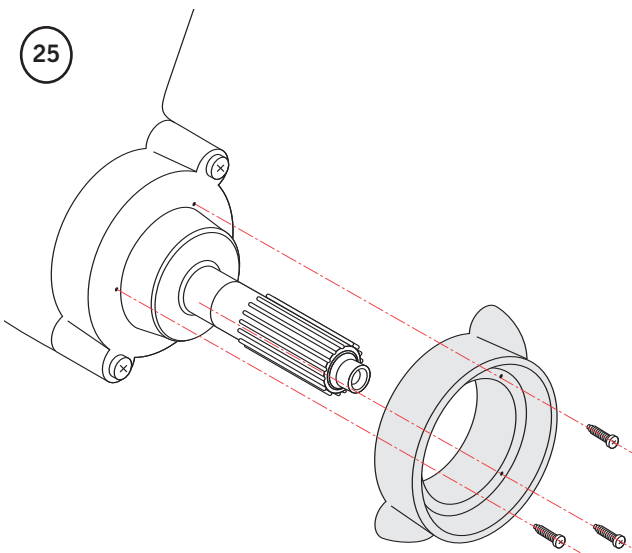

Always replace the zinc anode with all its new screws. Please tighten carefully as zinc is a soft metal, you will need to re-tighten a couple of times to obtain a good fit.

The zinc anode protects the saildrive unit only and is not replaced by the propeller anode, which only protects the propeller.

⚠ WARNING!

Do not paint the saildrive leg zinc anode and tail (propeller) cone anode.

▼ CHANGING LUBRICATING OIL - BOAT ASHORE

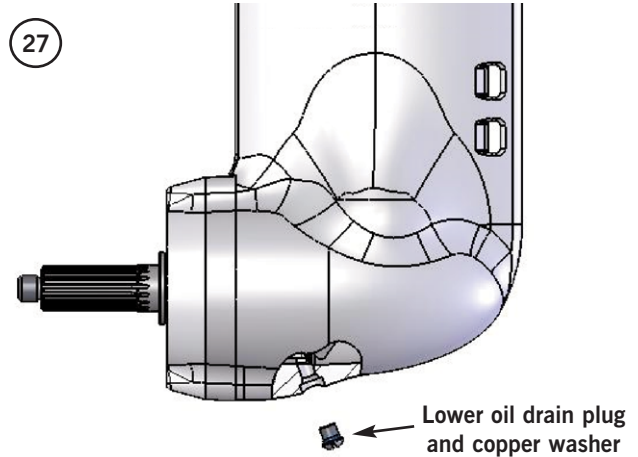
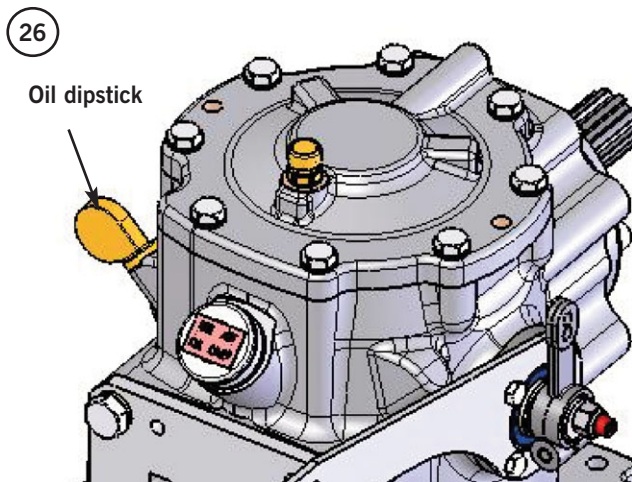

Lubricating oil can be drained through the drain hole in the base of the saildrive leg.

- 1) Remove dipstick.
- 2) Loosen and remove drain plug, (retaining or replacing the copper washer - as necessary).
- 3) To aid / improve oil flow, manually rotate the propeller / shaft.
- 4) Once oil has been fully drained, replace the dipstick.
- 5) Remove oil filler cap. Slowly pour in new oil until flows out the drain plug, then immediately replace the drain plug/copper washer and tighten.
- 6) Check the oil level using the dipstick, if necessary add more oil (oil quantity between the 'min' and 'max' on the dipstick is 0.15 liters).
- 7) Once oil has reached the 'max' level indicated on the dipstick, replace the oil filler cap and the dipstick.
- 8) Start engine and allow to idle for a few minutes, then turn the engine off and wait a few minutes before rechecking the level; if necessary top up.

▼ CHANGING LUBRICATING OIL - BOAT AFLOAT (SUCTION PUMP)

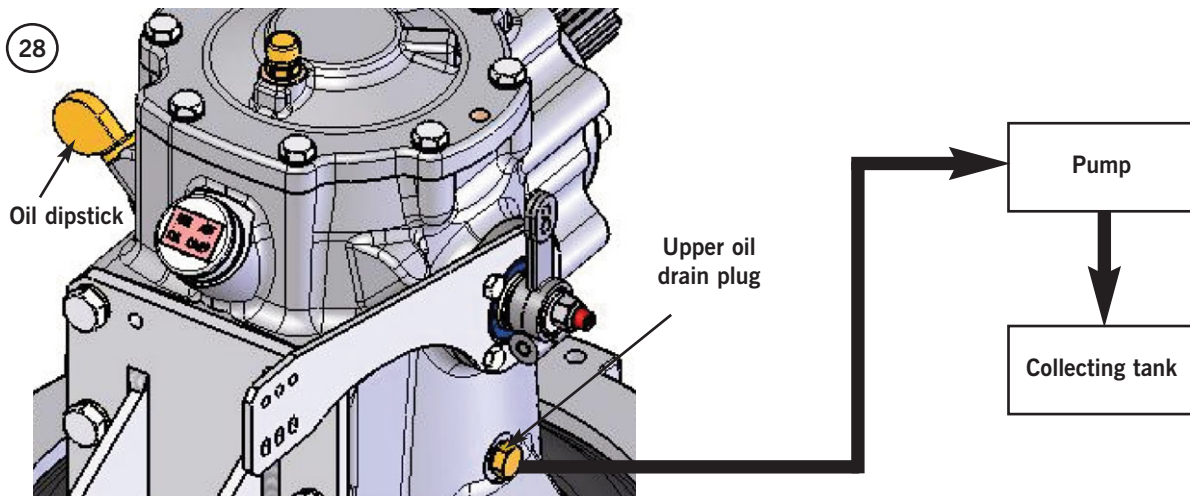

This method removes the oil by a manual suction pump from the oil drain plug on the side of the gearbox head.

- 1) Remove dipstick.
- 2) Loosen and remove upper drain plug, (retaining or replacing the copper washer - as necessary). Fit a union (threaded M10 x 1) with a flexible hose.
- 3) Connect the hose to a suitable suction pump and remove the used oil into a container.
- 4) Once oil has been fully drained, replace the dipstick and remove the suction pump connection.
- 5) Remove oil filler cap. Slowly pour in new oil until flows out the upper drain plug, then immediately replace the drain plug and tighten.
- 6) Check the oil level using the dipstick, if necessary add more oil (oil quantity between the 'min' and 'max' on the dipstick is 0.15 liters).
- 7) Once oil has reached the 'max' level indicated on the dipstick, replace the oil filler cap and the dipstick.
- 8) Start engine and allow to idle for a few minutes, then turn the engine off and wait a few minutes before rechecking the level; if necessary top up.

▼ CHANGING LUBRICATING OIL - BOAT AFLOAT (PRESSURE PUMP)

This method removes the oil by a manual pressure pump through the dipstick hole on the top of the gearbox head.

- 1) Remove dipstick.
- 2) Loosen and remove drain plug, (retaining or replacing the copper washer - as necessary). Fit a union (threaded M10 x 1) with a flexible hose.
- 3) Pump air into the oil system (using a hand or foot pump) through the dipstick hole. The hose connection allows the used oil to be drained into a suitable container.
- 4) Once oil has been fully drained, remove the pump and drain connection and replace the dipstick.
- 5) Remove oil filler cap. Slowly pour in new oil until it flows out the drain plug, then immediately replace the drain plug and tighten.
- 6) Check the oil level using the dipstick, if necessary add more oil (oil quantity between the 'min' and 'max' on the dipstick is 0.15 liters).
- 7) Once oil has reached the 'max' level indicated on the dipstick, replace the oil filler cap and the dipstick.
- 8) Start engine and allow to idle for a few minutes, then turn the engine off and wait a few minutes before rechecking the level; if necessary top up.

IMPORTANT!

Maximum pressure 0.5 bar / 50 KPa / 7.5 PSI.

Trouble-shooting

Problem: Vibration in Gear, No Vibration out of Gear	
Possible Cause	Solution
Engine tick over too low:	Adjust to 850 rpm, see engine operators manual.
Fouled propeller:	Try reverse gear to free. Get a diver down or slip boat for inspection.
Propeller blade damaged or missing:	Get a diver down or slip boat for inspection.
Worn or lose anode:	Replace zinc anode.

Problem: Saildrive will Not Engage Ahead / Reverse	
Possible Cause	Solution
Control cable adjusted incorrectly:	Disconnect control cable and try changing gear by hand, if ok attach cable and readjust. Contact Marine Engineer to replace broken or incorrectly fitted cable.
Broken drive plate:	Contact Marine Engineer.
Saildrive ceased:	Check oil level. Contact Marine Engineer.

Problem: Low sea water flow	
Possible Cause	Solution
Sea water inlet in leg covered by plastic bag or blocked by sea weed:	Clean sea water inlet.

Technical Specifications

Saildrive	Standard	Optional
Reduction ratio	2.15:1	2.38:1
Maximum input power	49 kW @ 3,000 rpm	44 kW @ 3,600 rpm
Maximum input speed (rpm)	3,800 rpm	
Maximum propeller diameter	18 inches / 450 mm	
Propeller shaft spline	Volvo standard: SAE J ¹⁶ / ₃₂ inch diameter with 17 teeth	
Nett dry weight (kg)	35 Kg	
Lubricating oil (litres)	ATF with a capacity of 3 litres	

SeaProp 60 - Features

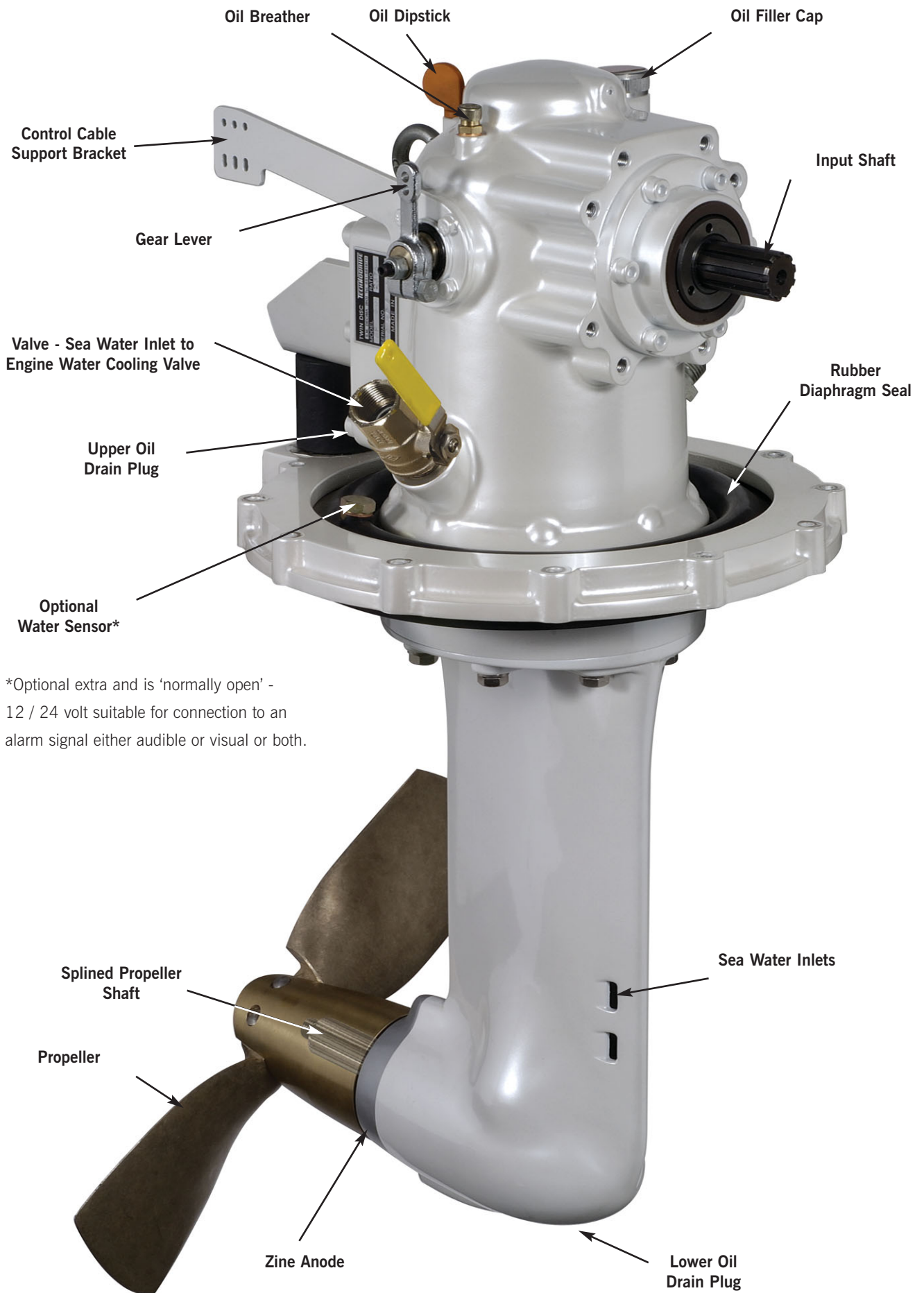

*Optional extra and is 'normally open' - 12 / 24 volt suitable for connection to an alarm signal either audible or visual or both.

Heat Exchanger Cooled
10 to 150bhp

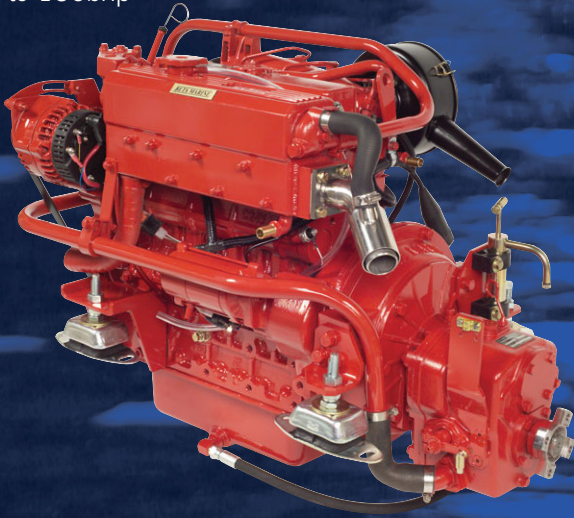

Keel Cooled
10 to 150bhp

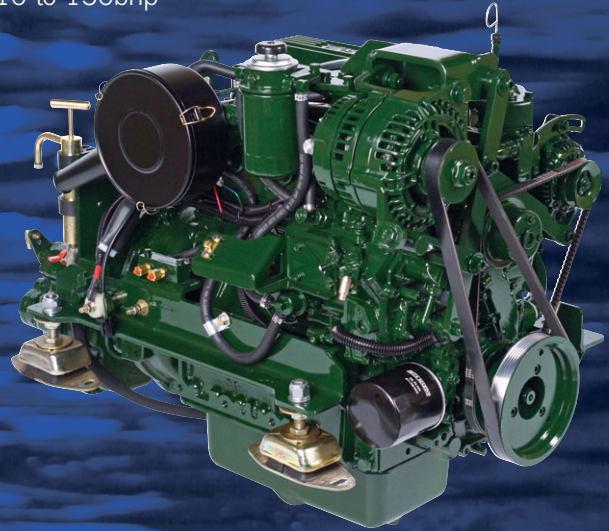

Marine Generating Sets
4 to 40kVA

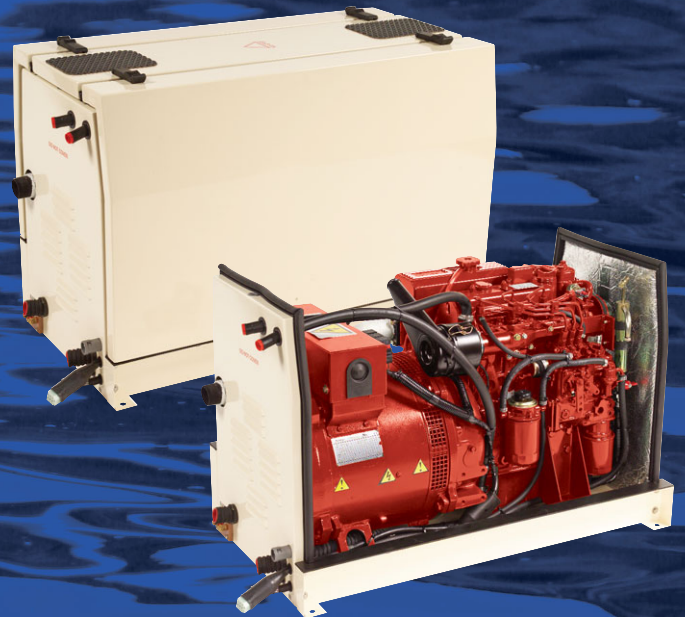

Sail Drives
13.5 to 56bhp

BETA MARINE

Beta Marine Limited
Davy Way, Waterwells
Quedgeley, Gloucester
GL2 2AD, UK.

Tel: 01452 723492
Fax: 01452 883742
Email: sales@betamarine.co.uk
www.betamarine.co.uk

Ref: 1790, July 2012.

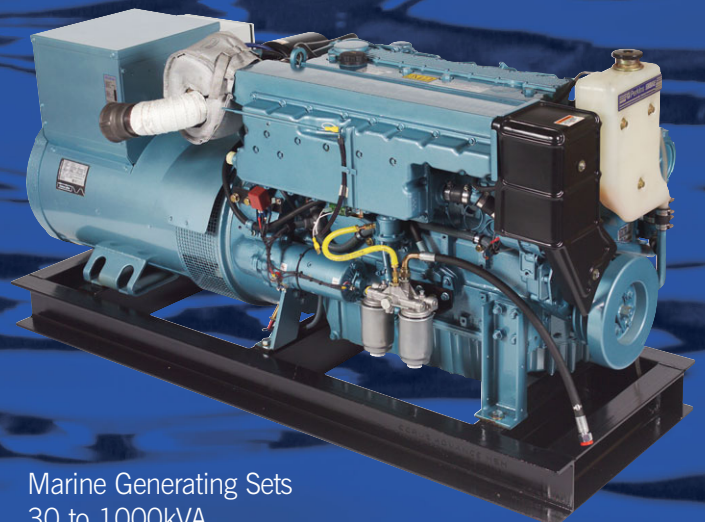

Marine Generating Sets
30 to 1000kVA